

# A FULL DUPLEX TELEMETRY SYSTEM FOR LONG DURATION STRATOSPHERIC BALLOONS

**S. Cecchini<sup>(1)</sup>, S. Cortiglioni<sup>(1)</sup>, E. Caroli<sup>(1)</sup>, L. Magistri<sup>(2)</sup>, J. Monari<sup>(3)</sup>, A. Esposito<sup>(4)</sup>, C. Pianese<sup>(4)</sup>, E. Ronchi<sup>(5)</sup>**

<sup>(1)</sup>INAF –IASF, via P. Gobetti 101, 40129 Bologna, Italy, [cecchini@bo.infn.it](mailto:cecchini@bo.infn.it)

<sup>(2)</sup>DMSET, Università di Genova, via Montallegro 1, 16145 Genova, Italy; [Loredana.Magistro@unige.it](mailto:Loredana.Magistro@unige.it)

<sup>(3)</sup>INAF – IRA, via P. Gobetti 101, 40129 Bologna, Italy; [j.monari@ira.inaf.it](mailto:j.monari@ira.inaf.it)

<sup>(4)</sup>Dept. of Mechanical Engineering - University of Salerno; [angesposito@unisa.it](mailto:angesposito@unisa.it)

<sup>(5)</sup>LEN S.r.l., via S. Andrea di Rovereto 33, 16043 Chiavari (GE), Italy; [len@len.it](mailto:len@len.it)

## ABSTRACT

A system able to provide up to 4.8 kbps real time bi-directional link for payloads onboard stratospheric balloons is presented. It has been developed to match the requirements of Long Duration Balloons, which are mainly flown from Polar regions, where ground infrastructures are often absent and/or rare. The apparatus has been customized and tested for using Iridium<sup>®</sup> based communications, even though it can be easily adapted to any other network/terminal. The equipment, in its basic flight configuration, has two Iridium<sup>®</sup> terminals and provides full Telemetry and Telecommands capabilities together with several I/O channels, onboard data storage, backup Li-Ion batteries, two GPS units, in a compact waterproof aluminium box. A S/W package for full control, data management, quick-look of both scientific and housekeeping data by a Ground Station (one or more PC laptops) that can be operated from everywhere has also been implemented. The undergoing development, that foresees an interface with a power system based on fuel cells, will be reported. The goal is to provide a complete (power supply and telemetry) system suitable for long duration flights particularly during winter (night time) seasons from Polar regions opening new opportunities for balloon programmes.

## 1. INTRODUCTION

Since many years high altitude balloon flights have provided scientists an alternative to more expensive, even in term of realization time, satellite based experiments. Flight durations have been growing from few days to the several weeks of recent Long Duration Balloon (LDB) flown from Antarctic regions, and plans are underway to provide missions up to months (Ultra LDB). To keep up with this evolving scenario, it is necessary to provide new communication systems, the so called Over-The-Horizon (OTH) communications. According to this scenario, since 2001 this group has started an activity for the development and implementation of equipments providing real time communications for LDB flights [1, 2, 3]. The payload weight and complexity grew as well, requiring

continuous updates of subsystems. In addition, the most favourable regions for LDB are Arctic and Antarctic polar areas, where ground based infrastructures are difficult to be realized and operated. Following the above considerations, our developments were driven by a flexible and modular philosophy and the use of the available global coverage network, namely Iridium<sup>®</sup>, to guarantee real-time continuous bi-directional links.

Our first step was the design of the *MSITel* (Multi Source Intelligent Telemetry) module [2], able to provide flexibility and multiple interfaces with on-board instrumentation. In *MSITel* philosophy the Ground Station(s) consists of laptop PC(s) and modem(s) that can be located everywhere. S/W packages have been developed and implemented allowing the module to perform all the operations suitable for flight management as well as full control and monitoring of payload instrumentation and data acquisition.

Features and capability of the current version (*MSITel-H\_V1.2*) will be presented in section 2. In section 3 we discuss some developments of the *MSITel* module that have been worked out to match special user requirements. Section 4 is dedicated to a current study for exploiting Fuel Cell power supply in future LDB.

## 2. *MSITel* MAIN FEATURES

*MSITel H\_V1.2* is a Control Telemetry Unit designed and tested to match the requirements of a communication system to be used onboard stratospheric balloons. Its design allows interface with one or more *intelligent* I/O units, like those foreseen for the BaR-SPOrt experiment [1, 4] for which it was firstly conceived. Being easily adaptable to all modems that are *AT command* compatible it has been tested up to bit-rate of about 115 kbps. The unit can communicate through different satellite systems such as Iridium<sup>®</sup>, Inmarsat, Globalstar, Thuraya as well as any other terrestrial systems. No H/W changes are required, only the S/W needs to be adapted accordingly. The present version has been optimized and tested for Iridium<sup>®</sup> platform, which is the one able to guarantee full coverage all over the World. The modems used are by

NAL Research (mod. A3LA-D). *MSITel H\_V1.2* hardware unit has 2 GPS units integrated with external antennas and several I/O, both analog and digital, for a direct control of external instrumentation. Six digital outputs are 0.5 A actuators, managed with a *high*

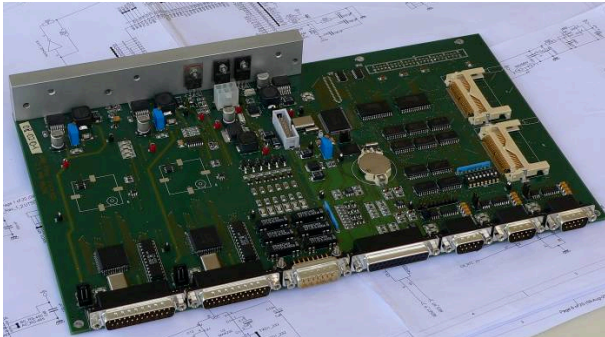

Figure 1. The *MSITel H\_V1.2* mainboard.

*security* H/W and S/W logic and suitable for no-back operation such as balloon-payload detachment (flight termination), ballast release, etc.... All digital inputs are protected against extra voltages and integrated for a time of 10 msec (adjustable). All the external instrumentation communicates with the unit either through RS232 or RS485.

Module specifications are listed below:

- Power Supply Voltage range: 9-40VDC
- Operating Temperature range: -40°C to +50°C
- Operating pressure: tested from 1000 mBar down to  $\leq 1$ mBar
- Unit size: 323mm x 189mm x 35mm (mainboard);

*MSITel H\_V1.2* has the following main features:

- One 115 kbps serial port, dedicated to scientific data, operating either in *burst mode* or *on-demand mode*
- Two serial channels, dedicated to housekeeping data from external instrumentation, operating in *on-demand mode*.
- Data acquisition of the local I/O according to the macro-language instructions.
- 6 digital outputs, reed relays buffered, max 0.5A
- 8 digital inputs (0-5 V)
- 6 digital output, buffered, max 100 mA @50V
- 2 analog outputs 10mA @6 V max
- 4 analog inputs, 5 V fr
- Power consumption, 250 mA@12V in standby mode

The unit has the following functionalities:

- Management of two Iridium<sup>®</sup> (or Hayes compatible) modem devices, that can set to operate either in *backup mode* (2400 bps) or in *split mode* (4800 bps)
- Management of the 2 integrated GPS units

- Polling of the external instrumentation both by direct user commands and by user-defined instructions (by macro-language). All communications are carried out through serial line connection (RS232 or RS485 standard).
- Storage of the acquired data into non-volatile support (Compact Flash).
- Sending of the acquired data, through the satellite line, to the Ground Station with a special protocol, according to the meta-language instructions (down-link telemetry).
- Execution of commands received by the Ground Station (up-link telemetry).
- Management of data to be addressed to other onboard (external) units

The *MSITel* board unit has also additional sensors for monitoring Power Supply Voltage, internal VDC and the unit actual temperature.

The equipment allows extended function customization according to user defined instruction (by meta-language scripts). This capability to be programmed by an easy-to-use interface makes the system absolutely peculiar with respect to other devices that employ modem communications. In such a way *MSITel* is able to satisfy most of requirements of both service and scientific balloon platforms.

All the data acquired by the unit, even if not transmitted according to priority rules (user defined), are stored in compact flash cards (up to 8 Gbytes). *MSITel H\_V1.2* makes use of a *realtime clock*, synchronized with onboard GPS, to provide absolute timing for the data storage. This assures a safe time correlation for all stored events. The connection with the modems (both the master and the back-up units) is provided by a 9-wire RS-232 serial line (hardware handshake). The power supply to each modem unit is provided separately. The bandwidth can be doubled by using both the onboard modem units (*split mode*), simultaneously.

More than one *MSITel* module, up to height, can be used to have higher (up to 38400 bps) telemetry bit-rate by using an additional unit (for example a “data collector”, see STRADIUM-LDB evolution in section 4).

### 3. *MSITel H\_V1.2* MODULE SOFTWARE

When using *MSITel* based telemetry systems, the Ground Station console can consist in one or more laptop PCs and, in absence of standard telephone line, at least one Iridium<sup>®</sup> modem. The *MSITel* S/W, however, will allow to customize the Ground Station following the user requirements.

In order to demonstrate the capabilities of the system

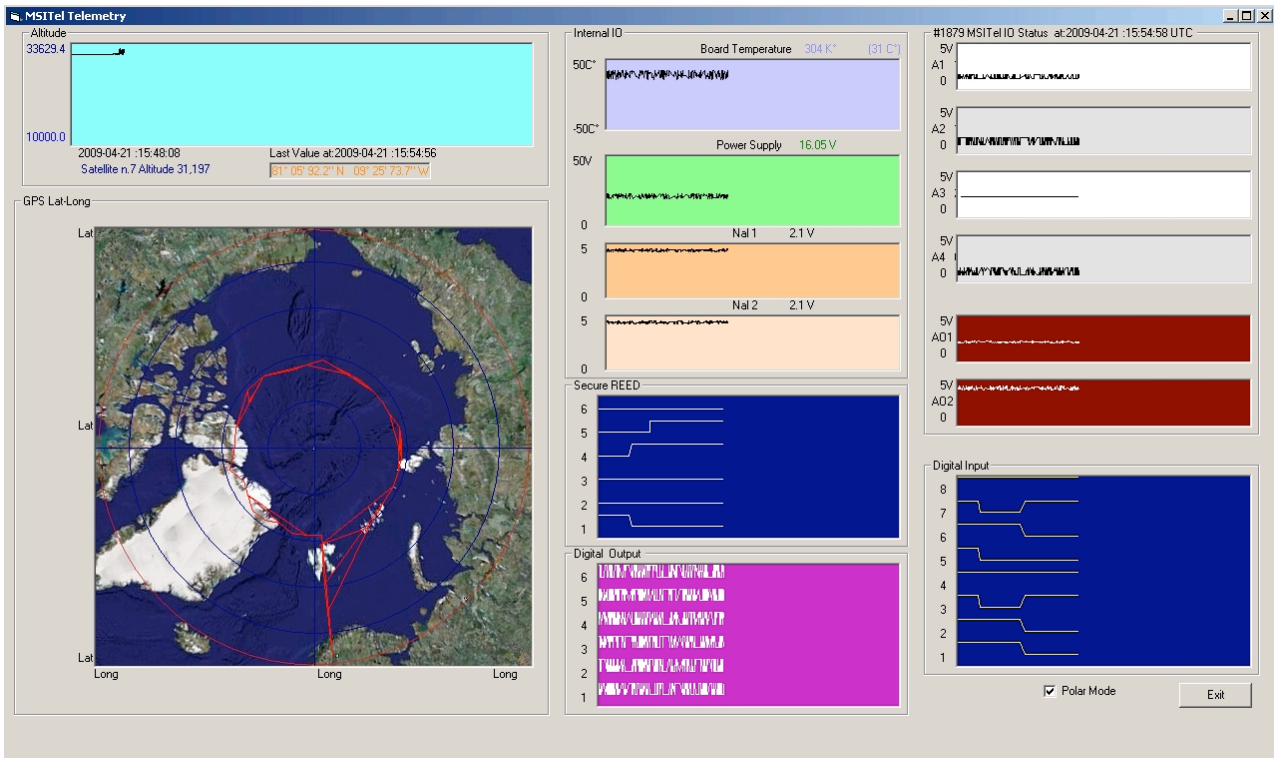

Figure 2. An example of graphic user interface (GUI) for the Ground Station implemented in the MSITel S/W

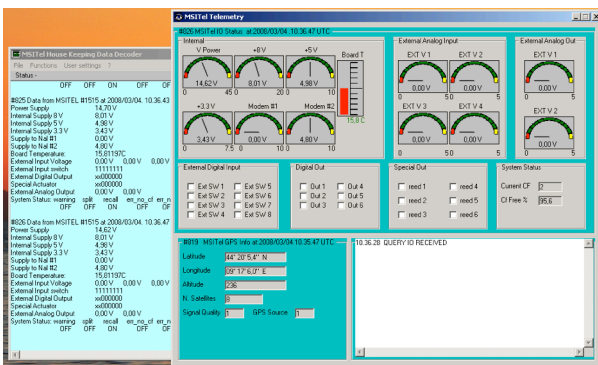

Figure 3. An example of on screen graphic display (or GUI) provided by the Ground Station already implemented in MSITel S/W

here we show (figures 2, 3) some examples of graphic user interfaces (GUI) built in the MSITel S/W that allow to perform several tasks for controlling different parameters of the payload functions. The S/W packages and the relative performed tasks are listed here below:

- MSITel\_Compiler: Parser, Compiler and CF image generator of Metalanguage script
- MSITel\_DCF: Decoder of data stored into CF during operations
- MSITel Link\_Decoder: Software for connection to remote MSITel, decoder of real-time telemetry-down data, encoder of tele-commands for

telemetry-up, LAN and Ethernet data sharing and data storage

- MSITelHK: decoder for housekeeping channel, LAN and Ethernet data sharing or local data
- MSITelScd: decoder for scientific channel, LAN and Ethernet data sharing or local data
- Quick-Look of both scientific and housekeeping data.

If needed, the users can create their own Ground Station software and Quick-Look by following instructions and protocol extensively described into Technical and User Manuals. All the implemented softwares work on Windows® Operating System (Windows® 98/ 2000/ 2003 server /XP).

#### 4. THE MSITEL SPECIAL APPLICATIONS (STRADIUM-LDB)

The MSITel has been used as the basic module of a system, named STRADIUM-LDB [3], realized to satisfy the following requirements proposed by ASI:

- Provide an easy and low cost way to access LDB flights carrying complex and demanding scientific payloads
- Provide a Primary Telemetry unit able to safely manage OTH flights
- Provide a Scientific Telemetry unit able to ensure bit-rate as high as 38400 bps for LDB scientific payloads

- Manage safely the Power Supply to LDB scientific payloads from different power source ( e.g. solar array, fuel cells, batteries)

The STRADIUM-LDB prototype (figures 4, 5, 6) has been built by using four *MSITel* units, one for Primary Telemetry (2.4-4.8 kbps) and three for Scientific Telemetry (14.4 kbps), and was successfully tested in 2008.

STRADIUM-LDB manages 14.4 kbps of scientific and housekeeping data, that are unpacked and sent to ground station by six NAL AL3A-D Iridium® modems. The ground station S/W will restore the original data frame and provides quick-look, storage and multiple access of data.



Figura 4 - The STRADIUM-LDB ground station Primary Telemetry

## 5. QUALIFICATION (GROUND) TESTS

The *MSITel* qualification tests have been done in the Thermo-Vacuum Chamber facility of the INAF-IASF institute in Bologna. The tests were performed by replicating the environmental conditions of a stratospheric flight, in the -50/+60 °C and 1000±1 mBar ranges of temperature and pressure, respectively. The tests were done without any thermal insulation of devices, to look for the real (intrinsic) operating constraints, and lasted few days. The test procedures have included, among others, the following situations:

- Switch on-off sequences of power supply, even at the lowest temperature, and up to one hour
- Several cycles of interruptions-recovering of Iridium® and GPS signals

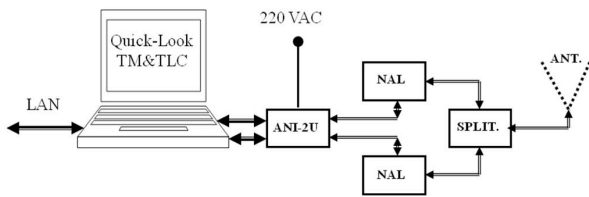
Similar tests have been carried out also for the flight equipment of STRADIUM-LDB. Even in this case the system has responded positively to the test in all its functionalities.

## 6. FLIGHT TESTS

All the tests demonstrated the reliability of the system and its capability to recover full functionality as soon as operating conditions were restored.

In the Summer 2008 the Science services department (Swedish Space Corporation) at Esrange launched a test

balloon that in five days landed in Canada. The purpose of the flight was to test systems like solar panels, batteries, battery charge units and power distribution system, and see how they behaved during a long flight.

A *MSITel* module was added as part of the telemetry system and used as communication link. The *MSITel* unit was placed in the gondola and two NAL Iridium® modems were used. The unit was connected to other onboard equipments via serial interface. Therefore charge and used voltages and currents from solar array and batteries could be read; temperatures on solar panels and gondola structure were measured as well; currents to each end user were monitored and, when necessary, there was a possibility to turn users on/off via the power distribution system. The built-in GPS function of *MSITel* was also employed to monitor balloon position and height.

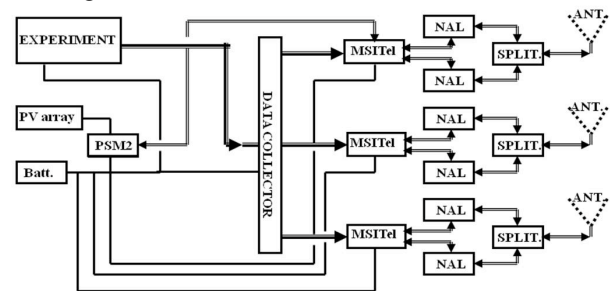

Figure 5-The STRADIUM-LDB Scientific Telemetry system (flight equipment) with 3 *MSITel* units

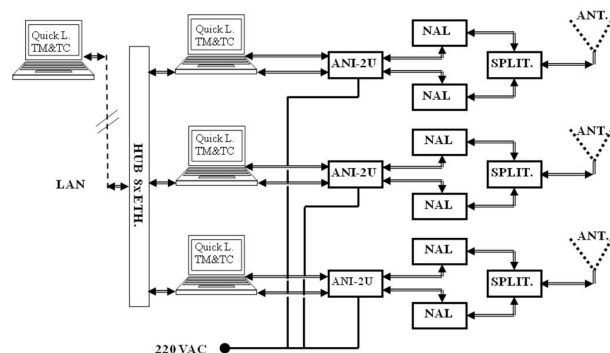

Figure 6 – The STRADIUM-LDB Scientific Telemetry system (ground equipment) with 3 *MSITel* units.

As part of the test the main input power to *MSITel* has been toggled a couple of times during flight and the unit always restarted. The communication via *MSITel* worked well and there were no stability problems.

## 7. CURRENT DEVELOPMENTS FOR FUEL CELL POWER EXPLOITATION

According to the goal to provide a complete (power supply and telemetry) platform for LDBs to be flown

during winter (night time) from Polar regions, the on-board power requirement will be supplied with an air - independent PEMFC (Proton Exchange Membrane Fuel Cell) system coupled with an energy storage system (battery pack). The application requires the utilization of pure oxygen and hydrogen as reactant gases. In comparison with conventional PEM fuel cells, the absence of nitrogen causes higher concentration of oxygen and water at the cathode, drastically reducing the oxygen diffusion resistance and enhancing PEMFC performance. If on one hand, this assures also membrane hydration, on the other hand, it asks for a more careful water management as excess water has to be removed from the electrode to prevent flooding occurrence. Furthermore, the two-phase water management is particularly critical considering that the cell operates at a temperature around 80 °C. Gas recirculation with water separation is done on both sides to avoid gas emission into the environment and to achieve maximum efficiency.

Figure 7 shows a simplified scheme of a PEMFC stack equipped with the needed auxiliaries and actuators (balance of plant). It is characterized to be suitable for integration into the power supply system of the LDB [5-7]. Some devices (e.g. humidifier, cooling fan) can be removed according to the final design of the entire system and to the control strategies selected for water and thermal management.

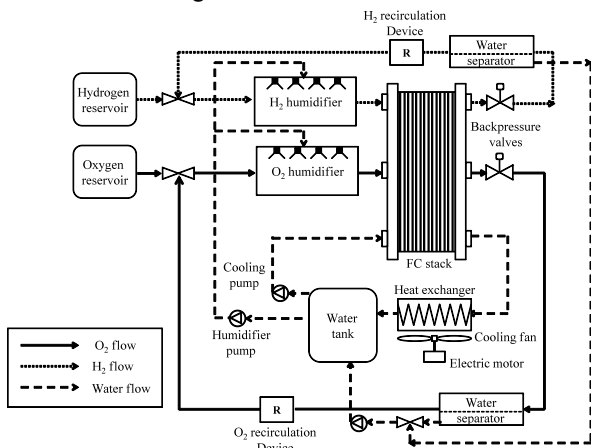

Figure 7 – Schematic PEMFC balance of plant [5-7].

Ad-hoc control strategies and monitoring algorithms will be built to detect system failures and fault modes. In the pursuit of describing the system peculiarities and designing control strategies, several numerical models of the PEM fuel cell stack will be implemented [5-7]. The problems concerning the integrated control, not yet fully investigated, will be approached; particular attention will be devoted to humidification and supply of reactant gases as well as to system water and thermal management [8, 9]. The models structure definition and

the experimental characterization will be conducted through a dedicated methodological study.

The FCS controller will have two levels (Figure 8), one for the electrical load management and the other one for the stack output power. The higher level controller (HLC) will set the power split between stack and battery pack. The control will be actuated adjusting the input and output DC/DC converter voltages. A map will be built to relate power split, battery state of charge, electrical load and stack operating point. For instance, the stack output power could be decreased to prevent water formation excess at the cathode side. Furthermore, the battery recharging power has to be kept within the maximum prescribed limit. During the LDB mission, the map can be updated with respect to decisions taken by the Ground Station (GS), based also on the information derived by the monitoring. At the lower control level, the numerical models will be used to determine the optimal (most efficient) stack set-points. The low level controller (LLC) will have to: i) avoid oxygen and/or hydrogen starvation; ii) ensure cathode and anode optimal pressure; iii) guarantee optimal membrane water content; iv) keep the stack thermal state within recommended boundaries. The control actions will be actuated via valves to regulate pressure and flow rates of the reactant and recirculated streams. The LLC will also control the DC/DC converter to fix the set-points derived by the HLC with an adaptive criterion of maximum efficiency. The system monitoring will serve to verify the stack operating conditions and evaluate possible modification to apply to the control system. The variables measured on the stack will be available thanks to the MSITel.

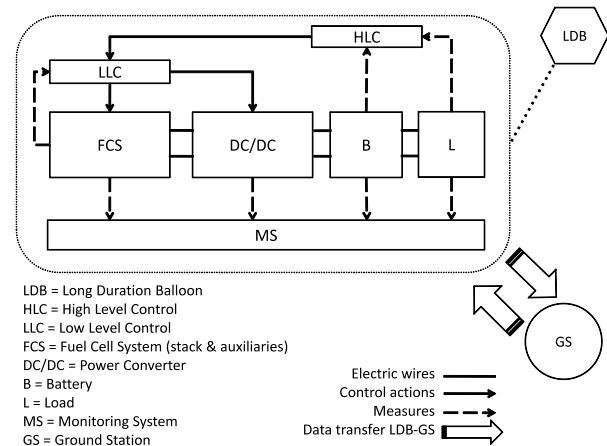

Figure 8 - Control scheme of the power generation unit.

## 8. CONCLUSIONS

The MSITel module, in its current version (H\_V1.2), has capabilities already suitable to satisfy most of LDB requirements.

One of the major characteristics of the system is flexibility, allowing different configurations where the unit can be used both as *service telemetry module* and as *experiment telemetry module*. In the latter case it is possible to exploit up to 8 *MSITel* modules for maximum allowed bit-rate, by using the additional Data Collector unit (see Fig. 5). Multiple *MSITel* units can be used also for managing many numerous I/O channels. Moreover, the use of the Power Supply Unit developed to work with *MSITel*, will improve the system overall efficiency. This unit, in fact, has the possibility of efficiently managing the power supply from different power sources (batteries, PV arrays, Fuel Cells, etc.) by sending power supply data to the Ground Station console.

Redundancy (active) of the system is assured in two ways: a) couple of modems can be operated so to have a second link always available in case of failure; b) the implemented firmware assures the resuming of communications via phone call by the on-board system as soon as satellite link becomes again available.

In any case a flash card provide storage of time-tagged data on-board. These latter will be sent at ground station in empty windows of the telemetry, when available.

Finally the great potentiality of the *MSITel* design resides in the possibility to adapt its functionalities to specific experimenter requirements by modifying the firmware, meta-language scripts, and the real-time graphic display of housekeeping and scientific data.

This system has already been tested in one over the Arctic balloon flight in 2008 and another service flight is foreseen also from the Arctic in the summer 2009.

As a further development we are currently studying the possibility to interface the system with a power system based on fuel cells, e.g. PEMFC. Special methodologies will be applied in order to have a full characterization of the complete power system apt to balloon flight during winter from the polar regions.

#### ACKNOWLEDGEMENTS

We thank A. Nyström, Science Services Division, Esrange, Swedish Space Corporation, Kiruna (Sweden) for sending us information about the test flight with *MSITel*. The Italian Space Agency (ASI) and the STRADIUM collaboration greatly contributed to the realization of the STRADIUM-LDB system. EXERGY FUEL CELLS, as part of the MORPHIC Group, is here acknowledge for providing industrial support to Fuel Cells developments for stratospheric balloon

applications

#### REFERENCES

1. Cortiglioni S. et al, *16<sup>th</sup> ESA Symposium* ESA-SP 530 (2003)
2. Cortiglioni S. et al, *17<sup>th</sup> ESA Symposium* ESA (2005)
3. Ronchi E. et al. (STRADIUM Coll.), *Mem. SAI* 79, 926-, 2008.
4. Zannoni M. et al, arXiv:astro-ph/0301020
5. Arsie I. , A. Di Domenico, C. Pianese, and M. Sorrentino, *Transaction of the ASME - Journal of Fuel Cell Science and Technology*, Vol. 4 (2007), pp. 261-271, ISSN 1550-624X.
6. Di Domenico A., A. Esposito, Y.G. Guezennec, and A. Miotti, *Proceedings of ASME 2006 The 4th International Conferences on Fuel Cell Science, Engineering and Technology*, June 19-21, 2006, Irvine, California, USA.
7. Arsie I., A. Di Domenico, C. Pianese, and M. Sorrentino, *Transaction of the ASME - Journal of Fuel Cell Science and Technology*, (in press), (2009).
8. Esposito, A., Y.G. Guezennec, and C. Pianese, *2008 ASME International Mechanical Engineering Congress and Exposition*, October 31-November 6, Boston, USA.
9. Esposito A., A. Montello, C. Pianese, and Y.G. Guezennec, *Proceeding of Fuel Cell 2009* (FuelCell2009-85166), June 2009.